



Terminales de Aluminio



FUSSE

ACA	23
ACA2	23
ACA E	24
ACA FJ	24
ACB	25
AE	26
PE	26
GR	26



TERMINALES DE ALUMINIO

Para identificar o comprimir en conductores de Aluminio

TIPO UN AGUJERO Y DOBLE IDENTACIÓN

ACA

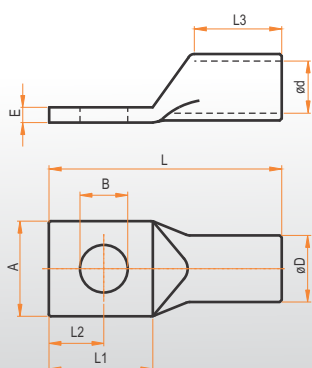

! Nota: No se recomienda su utilización en conductores de cobre, con el fin de evitar el par galvánico.



SECCIÓN mm ²	DIMENSIONES										CÓDIGO
	A	B	B''	øD	ød	E	L	L1	L2	L3	
6	12,0	7,0	1/4	7,1	3,8	2,4	35,9	16,0	7,0	15,0	ACA 6
10	13,0	7,0	1/4	7,5	4,5	2,3	35,7	16,0	7,0	15,0	ACA 10-1
	16,0	8,3	5/16	8,5	4,5	2,7	43,3	17,7	8,6	20,0	ACA 10-2
16	18,5	8,3	5/16	9,1	5,6	2,4	50,6	24,0	11,0	20,0	ACA 16
25	21,5	8,3	5/16	11,0	6,9	2,6	59,0	29,5	14,5	20,0	ACA 25
35	20,0	7,0	1/4	12,7	8,2	3,5	56,8	27,5	13,3	20,0	ACA 35-1
	23,5	10,5	3/8	12,7	8,2	3,0	57,5	27,5	13,0	20,0	ACA 35-2
50	24,0	10,5	3/8	15,0	9,8	4,0	70,0	25,3	12,5	33,0	ACA 50-1
	27,0	14,0	1/2	15,0	9,8	3,4	80,0	34,0	16,0	33,0	ACA 50-2
70	30,0	14,0	1/2	17,4	11,5	3,7	83,5	34,0	16,0	37,0	ACA 70-1
	32,0	17,0	5/8	17,4	11,5	3,8	91,5	42,0	19,0	37,0	ACA 70-2
95	32,0	14,0	1/2	19,4	13,5	4,3	88,5	34,0	16,0	38,0	ACA 95
120	34,5	14,0	1/2	23,5	15,2	7,5	96,5	34,0	16,0	40,0	ACA 120
150	38,0	17,0	5/8	25,4	16,5	7,7	109,0	42,0	19,0	47,0	ACA 150
185	40,0	17,0	5/8	28,5	18,6	9,1	113,0	42,0	19,0	50,0	ACA 185
240	45,0	17,0	5/8	31,7	20,8	10,0	121,0	42,0	19,0	56,0	ACA 240
300	49,0	17,0	5/8	36,5	23,5	12,2	137,1	45,0	22,5	65,0	ACA 300
400	57,0	17,0	5/8	42,0	27,5	13,0	155,1	45,0	22,5	80,0	ACA 400
500	62,0	17,0	5/8	47,0	30,5	13,5	172,0	49,0	24,0	90,0	ACA 500
630	64,0	17,0	5/8	50,0	36,0	14,0	182,0	49,0	24,0	100,0	ACA 630
800	66,0	17,0	5/8	54,0	40,0	14,0	195,0	55,0	26,0	110,0	ACA 800

Terminales para identificar o comprimir en conductores de aluminio de BT y MT fabricados a partir de caño de aluminio de sección apropiada y conductividad mínima de 59% IACS, sin ventana

de inspección, lo cual lo convierte, por su condición de estanco, en un producto apto para el uso en la intemperie en posición vertical.

TIPO DOS AGUJEROS Y DOBLE IDENTACIÓN

ACA2

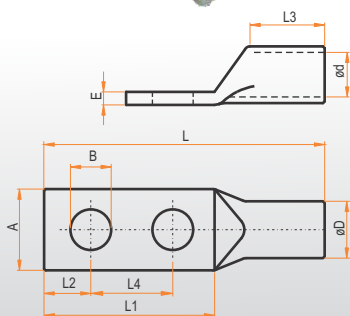

! Nota: No se recomienda su utilización en conductores de cobre, con el fin de evitar el par galvánico.



SECCIÓN mm ²	DIMENSIONES										CÓDIGO	
	A	B	B''	øD	ød	E	L	L1	L2	L3		L4
70	30,0	14,0	1/2	17,4	11,5	5,5	128,5	79,0	16,0	37,0	45,0	ACA2 70
95	32,0	14,0	1/2	19,4	13,5	4,3	133,5	79,0	16,0	38,0	45,0	ACA2 95
120	34,5	14,0	1/2	23,8	15,2	7,9	141,5	79,0	16,0	40,0	45,0	ACA2 120
150	38,0	14,0	1/2	25,4	16,5	7,0	146,0	79,0	16,0	47,0	45,0	ACA2 150
185	40,0	14,0	1/2	28,5	18,6	9,2	150,0	79,0	16,0	50,0	45,0	ACA2 185
240	45,0	14,0	1/2	31,7	20,8	10,5	158,0	79,0	16,0	56,0	45,0	ACA2 240
300	49,0	14,0	1/2	36,5	23,5	12,0	169,0	79,0	16,0	65,0	45,0	ACA2 300
400	57,0	14,0	1/2	42,0	27,5	13,7	185,0	79,0	16,0	80,0	45,0	ACA2 400

Terminales para identificar o comprimir en conductores de aluminio de BT y MT fabricados a partir de caño de aluminio de sección apropiada y conductividad mínima de 59% IACS, sin ventana de inspección, lo cual lo convierte, por su

condición de estanco, en un producto apto para el uso en la intemperie en posición vertical. La pala de doble agujero asegura una mejor fijación en artefactos que así lo requieran por sus condiciones de trabajo.

TERMINALES DE ALUMINIO

Para identificar o comprimir en conductores de Aluminio

TIPO UN AGUJERO Y DOBLE IDENTACIÓN



ACA E

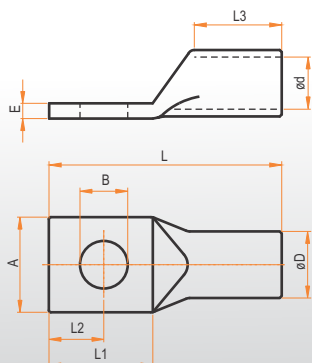

SECCIÓN mm ²	DIMENSIONES										CÓDIGO
	A	B	B''	øD	ød	E	L	L1	L2	L3	
6	12,0	7,0	1/4	7,1	3,8	2,4	35,9	16,0	7,0	15,0	ACA 6E
10	13,0	7,0	1/4	7,5	4,5	2,3	35,7	16,0	7,0	15,0	ACA 10-1E
	16,0	8,3	5/16	8,5	4,5	2,7	43,3	17,7	8,6	20,0	ACA 10-2E
16	18,5	8,3	5/16	9,1	5,6	2,4	50,6	24,0	11,0	20,0	ACA 16E
25	21,5	8,3	5/16	11,0	6,9	2,6	59,0	29,5	14,5	20,0	ACA 25E
35	20,0	7,0	1/4	12,7	8,2	3,5	56,8	27,5	13,3	20,0	ACA 35-1E
	23,5	10,5	3/8	12,7	8,2	3,0	57,5	27,5	13,0	20,0	ACA 35-2E
50	24,0	10,5	3/8	15,0	9,8	4,0	70,0	25,3	12,5	33,0	ACA 50-1E
	27,0	14,0	1/2	15,0	9,8	3,4	80,0	34,0	16,0	33,0	ACA 50-2E
70	30,0	14,0	1/2	17,4	11,5	3,7	83,5	34,0	16,0	37,0	ACA 70-1E
	32,0	17,0	5/8	17,4	11,5	3,8	91,5	42,0	19,0	37,0	ACA 70-2E
95	32,0	14,0	1/2	19,4	13,5	4,3	88,5	34,0	16,0	38,0	ACA 95E
120	34,5	14,0	1/2	23,5	15,2	7,5	96,5	34,0	16,0	40,0	ACA 120E
150	38,0	17,0	5/8	25,4	16,5	7,7	109,0	42,0	19,0	47,0	ACA 150E
185	40,0	17,0	5/8	28,5	18,6	9,1	113,0	42,0	19,0	50,0	ACA 185E
240	45,0	17,0	5/8	31,7	20,8	10,0	121,0	42,0	19,0	56,0	ACA 240E
300	49,0	17,0	5/8	36,5	23,5	12,2	134,0	49,0	19,0	65,0	ACA 300E
400	57,0	17,0	5/8	42,0	27,5	13,7	152,0	54,0	19,0	80,0	ACA 400E
500	62,0	17,0	5/8	47,0	30,5	13,5	172,0	49,0	24,0	90,0	ACA 500E
630	64,0	17,0	5/8	50,0	36,0	14,0	182,0	49,0	24,0	100,0	ACA 630E
800	66,0	17,0	5/8	54,0	40,0	14,0	195,0	55,0	26,0	110,0	ACA 800E

Los Terminales de Aluminio estañados reúnen las mismas características que los ACA. Poseen un recubrimiento superficial de estaño aplicado por electrodeposición, asegurándose un mínimo

de 5 micrones, obteniendo de esta manera una buena protección contra la corrosión y dureza apropiada en el cañón para realizar con el mínimo esfuerzo una compresión ideal.

FORJADOS



ACA FJ

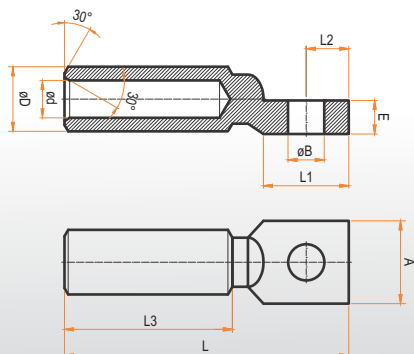

SECCIÓN mm ²	DIMENSIONES										CÓDIGO
	A	B	B''	øD	ød	E	L	L1	L2	L3	
16	32,0	14	1/2	20,0	5,5	8	90,0	33,0	16,5	48,0	ACA 16 FJ
25	32,0	14	1/2	20,0	7,0	8	90,0	33,0	16,5	48,0	ACA 25 FJ
35	32,0	14	1/2	20,0	8,2	8	90,0	33,0	16,5	48,0	ACA 35 FJ
50	32,0	14	1/2	20,0	9,8	8	90,0	33,0	16,5	48,0	ACA 50FJ
70	32,0	14	1/2	20,0	11,6	8	90,0	33,0	16,5	48,0	ACA 70 FJ
95	32,0	14	1/2	20,0	13,0	8	90,0	33,0	16,5	48,0	ACA 95 FJ
120	32,0	14	1/2	25,0	14,5	13	110,0	33,0	16,5	65,0	ACA 120 FJ
150	32,0	14	1/2	25,0	16,5	13	110,0	33,0	16,5	65,0	ACA 150 FJ
185	38,0	14	1/2	32,0	18,2	14	120,0	43,0	21,5	65,0	ACA 185 FJ
240	38,0	14	1/2	32,0	21,0	14	120,0	43,0	21,5	65,0	ACA 240 FJ
300	50,0	17	5/8	36,0	23,5	15	160,0	50,0	25,0	90,0	ACA 300 FJ

Terminales Forjados y Estañados para identificar o comprimir en conductores de aluminio de BT y MT fabricados a partir de barra de aluminio sin alea de conductividad mínima de 59% IACS, sin ventana de inspección, lo cual lo convierte, por su condición de estanco, en un producto apto para el

uso en la intemperie en posición vertical. Al estar estañados permite ser colocados en bornes tanto de aluminio como de cobre. La fabricación a través del proceso de forja y su robustez garantiza su colocación en aparatos sometidos a altos niveles de vibración.

TERMINALES BIMETÁLICOS

Para unir conductores de aluminio con barras o borneras de cobre



ACB

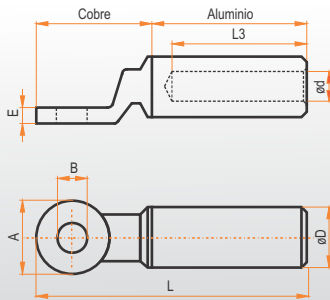

SECCIÓN mm ²	DIMENSIONES								CÓDIGO
	A	B	B"	øD	ød	E	L	L3	
16	20,0	10,5	3/8	16,0	5,5	4,5	79,0	43,0	ACB 16
25	20,0	10,5	3/8	16,0	6,5	4,5	79,0	43,0	ACB 25
35	25,0	12,8	1/2	16,0	8,0	5,0	79,0	43,0	ACB 35
50	25,0	12,8	1/2	20,0	9,0	5,0	85,0	43,0	ACB 50
70	25,0	12,8	1/2	20,0	11,0	5,0	85,0	43,0	ACB 70
95	25,0	12,8	1/2	20,0	12,5	5,0	85,0	43,0	ACB 95
120	30,0	12,8	1/2	25,0	13,7	6,0	106,0	59,0	ACB 120
150	30,0	12,8	1/2	25,0	15,5	6,0	106,0	59,0	ACB 150
185	30,0	12,8	1/2	32,0	17,0	6,0	110,0	59,0	ACB 185
240	30,0	12,8	1/2	32,0	19,5	6,0	110,0	59,0	ACB 240
300	30,0	12,8	1/2	34,0	23,3	7,0	110,0	59,0	ACB 300

El cañón está hecho a partir de barra de aluminio de sección apropiada, conductividad mínima de 59% IACS, sin ventana de inspección, lo cual lo convierte, por su condición de estanco, en un producto apto para el uso en la intemperie en posición vertical. A su vez la pala de cobre, de 98% IACS, está soldado a fricción en vacío al

cañón de aluminio de tal manera que ambos metales presentan la mejor conductividad posible de conseguir evitando la corrosión entre ambos. La fabricación a través del proceso de forja y su robustez garantiza su colocación en aparatos sometidos a altos niveles de vibración.

ARANDELAS BIMETÁLICAS Y GRASA ANTIOXIDANTE

ARANDELAS BIMETÁLICAS

AE

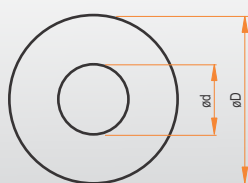

DIMENSIONES		P/TORNILLO		CÓDIGO
øD	ød	W	M	
13,0	3,5	1/8	3	AE 0350
14,5	4,4	5/32	4	AE 0440
16,0	5,3	3/16	5	AE 0530
18,0	7,0	1/4	6	AE 0700
20,0	8,8	5/16	8	AE 0880
24,1	10,5	3/8	10	AE 1050
28,0	12,2	7/16	11	AE 1220
32,0	13,9	1/2	13	AE 1390
35,0	17,3	5/8	16	AE 1730
45,0	20,0	3/4	19	AE 2000

Arandelas fabricadas a partir de fleje bimetalico para utilizar en conexiones entre terminales de aluminio y barras de cobre.

PLAQUETAS BIMETÁLICAS

PE

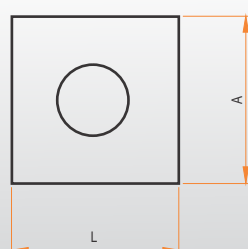
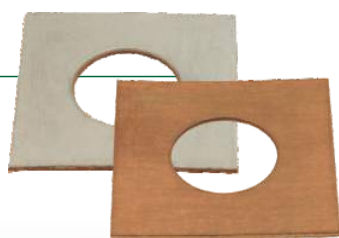

DIMENSIONES		P/TORNILLO		CÓDIGO
L	A	W	M	
17	17	5/16	8	PE 1025
23	23	3/8	10	PE 3550
30	30	1/2	13	PE 70120
35	35	5/8	16	PE 15085
45	45	5/8	16	PE 24300
A / PED.	70	SIN AGUJERO		PE 1000170

Plaquetas fabricadas a partir de fleje bimetalico para utilizar en conexiones entre terminales de aluminio y barras de cobre.

GRASA ANTIOXIDANTE

GR



PESO Gramos	CÓDIGO
200	GR 200G
500	GR 500G

Compuesto inhibidor para utilizar en conexiones eléctricas entre Aluminio-Aluminio o Cobre-Cobre.

Se debe colocar previo a la compresión, por ende las superficies de aplicación deben estar limpias. Este compuesto previene el óxido y aísla de la humedad aquellas posibles burbujas de aire generadas en la compresión. Su temperatura de trabajo es entre -15°C y 180°C.